

SLAM LATCH

INSTALL MANUAL & USERS GUIDE



TABLE OF CONTENTS .

01 Technical Dimension

02 Removal of Existing Slam Latch

03 Install New Slam Latch

04 Contact Us

WELCOME TO THE FAMILY!



Thanks for purchasing our Latch.it RV Door Lock! We are a family owned American business that cares about your safety and security!



Please review, read and understand ALL instructions to ensure proper functionality.

If you have any questions or concerns, don't hesitate to reach out to us, we are always available at info@latchit.org

SEE FULL VIDEO INSTRUCTIONS AT
www.latchit.org

01

TECHNICAL DIMENSION

FRONT VIEW

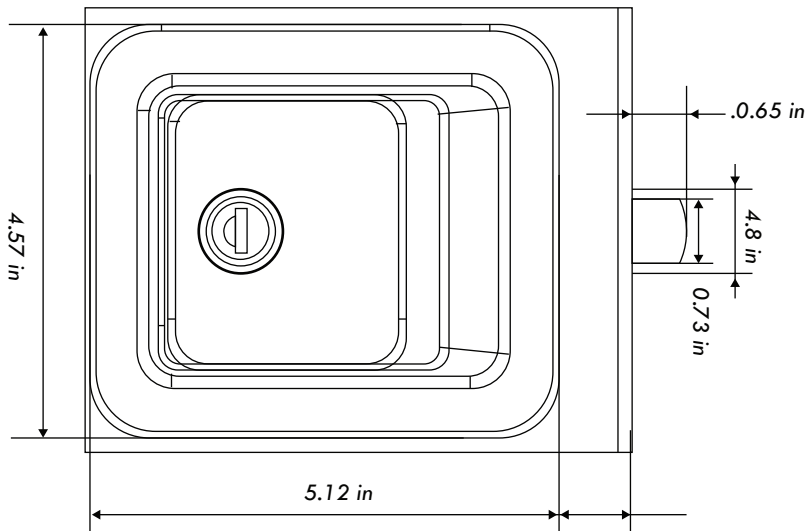

SIDE VIEW

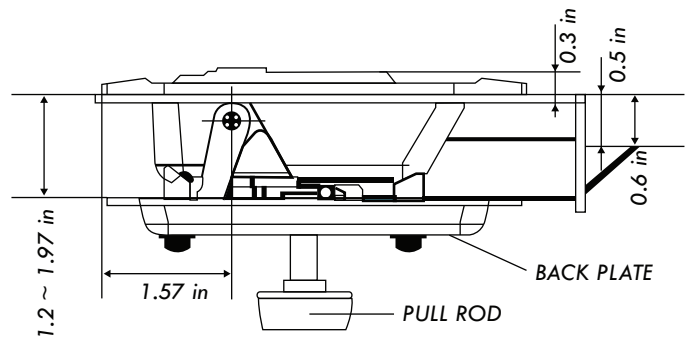

REAR VIEW

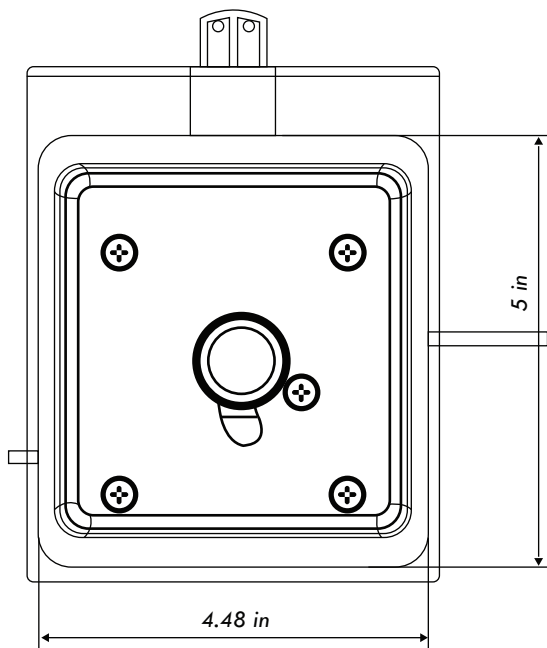

DOOR LOCK HOLE REQUIREMENTS

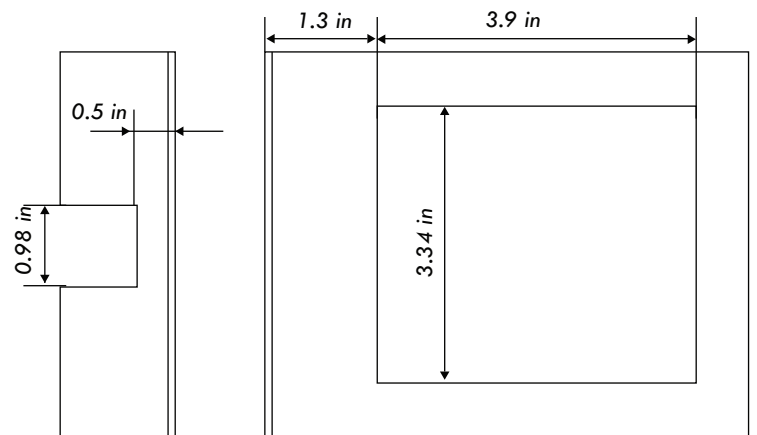

02

REMOVAL OF EXISTING SLAM LATCH

1. On the back plate of your OEM slam latch, unscrew all fasteners.

- *If the interior plate of your OEM slam latch has 4 permanent fasteners (rivets) holding it in place, you will be required to drill them out. Ensure you only drill the head and not through your entire baggage door.*

2. Remove interior plate and slam latch away from baggage

3. Clean the lock hole to ensure no debris or paint are in the way of the new slam latch install.

03

INSTALL NEW SLAM LATCH

1. Separate the front half assembly and metal backplate by removing the 4 fasteners and unscrewing the pull rod.
2. Install the front half assembly into the baggage door hole.
3. Line up the metal back plate with the front half assembly and hand tighten all fasteners (4) in place.
4. Using a screwdriver, tighten all 4 fasteners to firmly secure the front assembly and back plate together.
5. Re-install the pull rod by screwing it in place.
 - *Pull rod exists in case the slam latch may need to be opened from the inside (generally not the case so it may be left un-installed)*
6. Test out your door to ensure it open/closes smoothly and that it fully engages with the striker plate.
7. Loosening fasteners and re-adjusting the lock may be required to allow smooth operation.

04

CONTACT US

Scan with your smart phone camera to contact
LATCH.IT Support via the Official Website

www.latchit.org



Email us at info@latchit.org with any questions
or concerns, our support team is always available!

